

SOLAR PIR SENSOR LIGHT

Model: SM-210C

1. Mounting Bracket
2. Adjustment Support
3. Power Cable
4. Solar Cell Mounting Screws (X 3)
5. Solar Cell
6. Main Battery Unit
7. Main Housing Mounting Screws
(X 2)
8. Transparent Light Cover
9. PIR Sensor
10. AUTO / OFF Switch
11. Duration Time Adjusting Knob
12. Sensitivity Adjusting Knob
13. Lux Control Adjusting Knob

Important:

(1) Please ensure that you charge the solar lights in maximum sunlight for a period of up to 3 days before switching on the lights, in order that the lights work on a full charge.

■ HOW TO DETERMINE WHERE TO MOUNT YOUR SOLAR PIR SENSOR LIGHT

Note: In the Figure B position, it is important not to let rain enter the main unit. Make sure it is mounted in a covered area.

The most important thing to remember for the operation of your SOLAR PIR SENSOR LIGHT is that it works from the power contained in **DIRECT SUNLIGHT**. The more direct sunlight the solar cell receives in a day, the longer the light will operate.

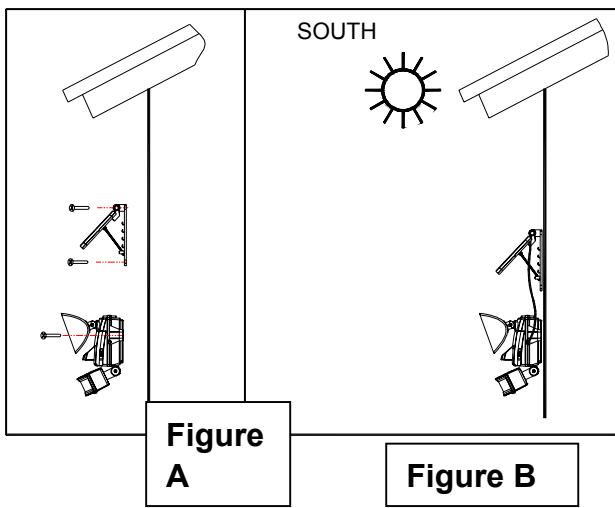

■ Main Unit:

The main unit contains the lamp (10Watt/6V G5.3 halogen bulb), motion sensor and battery (sealed Lead-Acid Rechargeable battery, 6V, 4Ah). When deciding where to mount this unit, keep in mind that the motion sensor that activates the light has a “field of vision” of min. 7 meters (in front of the light) and about 140° (horizontal) at 25°C environmental temperature.

To mount the unit vertically for use as a security type of light, attach the unit to a solid surface as shown in figure A. To mount the unit horizontally for use as a convenience type of light, attach the unit as shown in figure B. Use the two wood/ sheet metal screws supplied (#7 on parts list).

■ Solar Cell:

The solar cell is the power source for the SOLAR PIR SENSOR LIGHT. It converts the sun’s energy into electricity that charges the battery stored in main unit. This requires DIRECT SUNLIGHT falling onto the face of solar cell for as long as possible over the course of day.

Use the three wood/sheet metal screws supplied (#4 on parts list) to mount the solar cell unit onto a solid surface. Make sure it is anchored into the solid surface.

You can adjust the angle of the solar cell by moving the adjustment support to the appropriate hook on the

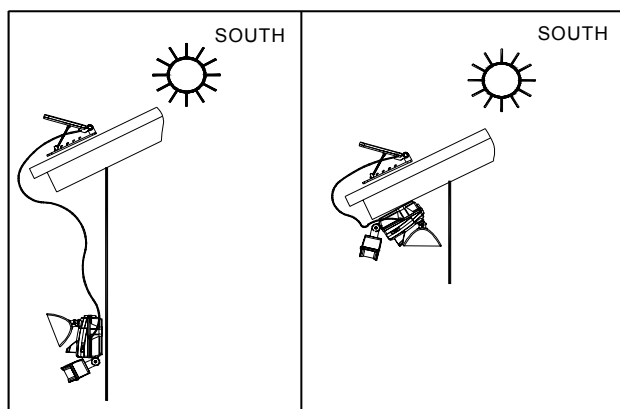

mounting bracket. Remember, it must face as much DIRECT SUNLIGHT over the course of the day as possible. Keep in mind shadows that may block sunlight at some point during the day.

Now carefully route the solar cell power cord to the main unit and plug it into the connector on the side of the unit.

Important: if the main unit is mounted horizontally, it must be mounted in a covered area so water will not get into the unit through the exposed vents.

■ FINAL ADJUSTMENT AND START-UP

After you successfully installed your SOLAR PIR SENSOR LIGHT, you are almost ready for carefree operation with a few final steps:

Initial 3-days Charge:



On the main unit there is a slide switch with 2 positions: ● OFF ● AUTO

AUTO —

Position for normal operation of unit.

OFF ---

- 1) Position for shipping or extended periods of non-use
- 2) Position for initial 3-day charge before final adjustment and first use. (Although the unit can charge, it is not operational in this mode)

For now, turn the slide switch to OFF position. In this position the solar cell will charge the battery without activating the unit. Leave the switch in this position for 3 sunny days to ensure that the battery has a full charge prior to motion sensor adjustment and normal operation.

■ HOW TO ADJUST THE MOTION SENSOR

After the initial 3-day charge, slide the switch on the main unit to AUTO position.

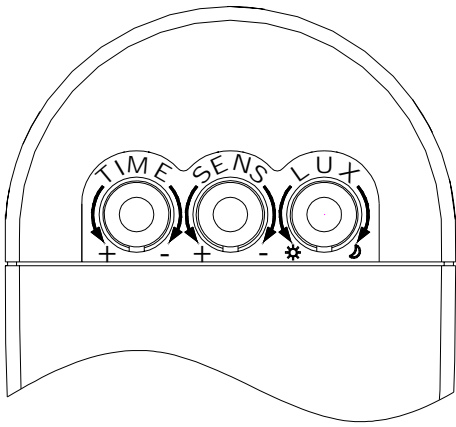

On the motion sensor there are three adjusting knobs: **TIME / SENS / LUX**

- 1) **TIME** --- Duration time: Depending on how long you wish the unit to stay lit after motion stops in the field of vision, the duration time will adjust from 10 seconds to 1 minute. **Note:** Once the light has been triggered by the PIR sensor any subsequent detection will start the timed period again from the beginning.
- 2) **SENS** – Sensitivity adjustment: The sensitivity of motion sensor will be affected by environment temperature. The more sensitivity for PIR sensor, the lower environment temperature. So you can adjust the SENS knob to compensate the change of sensitivity affected by environment temperature.
- 3) **LUX** – Lux control level: The Lux control module has a built-in sensing device (photocell) that detects daylight and darkness. (☀) position denotes that the lighting will be turned on by PIR during day and night, (☾) position denotes that the lighting will be turned on by PIR only at night. You can set to operate the unit at the desired level by adjusting the LUX knob.

Note: If, in daily position, the unit turns on when it is too light outside, turn the control towards (☾). However, if the light is not activating during nighttime because of a street light or bright house light, turn this control towards (☀).

Walking-test:

Point the motion sensor to face the area you want to detect motion in and set the TIME knob to minimum (-) position and LUX knob to “light” (☀) position. Walking slowly within its detection area, the sensor can detect moving invisible infra-red radiation given off by a human body and then turn on the light. Test the coverage of the area by walking slowly around until

not to switch on the light.

ADJUSTMENT OF THE LAMP HOUSING:

Point the lamp housing to face the area you wish to illuminate.

■ BULB AND BATTERY REPLACEMENT

Caution: When replacing the bulb or battery, the slide switch on the main unit must be in the **OFF** position.

■ Bulb Replacement:

Depending on the amount of use, the bulb in your SOLAR PIR SENSOR LIGHT is designed to have an average lifetime of half past one year. When it becomes necessary to replace the bulb, you can obtain a replacement from location agent.

The old bulb can be easily replaced by popping the transparent light cover (#8 in parts list) off with a screwdriver (there is a slot at one end of the cover) and pulling the bulb from its base. Reverse this procedure with the new bulb to reassemble.

(IMPORTANT: ☐ The bulb will be hot when the light is on, please let the bulb cool when replace the bulb. ☐ Be extremely careful when handling the bulb, especially if it is broken. Also, do not touch the bulb with bare hands / fingers as this will shorten bulb life.)

■ Battery Replacement:

The battery in your SOLAR PIR SENSOR LIGHT is designed to last for about 3 years. When it becomes necessary to replace the battery, you can obtain a replacement from location agent.

The old battery can be replaced by first removing the unit from its mounting surface. Then remove the screws on the back of the main unit which hold the halves together. Carefully unplug the positive and negative battery leads and unscrew the screws holding the battery retainer in place. Carefully remove the battery from its compartment and replace by reversing this procedure.

(Caution: Make sure the (+) and (-) leads are attached correctly to the appropriate (+) and (-) battery terminals. Serious damage to the unit may result if they are connected backwards.)

It is important to dispose of the battery in an environmentally conscious manner. Dispose of according to applicable governmental regulations.

Recyclable.

■ GENERAL ELECTRICAL AND SAFETY

WARNINGS

- 1) The AUTO/OFF switch on the main unit must be in the OFF position when changing the bulb or battery.
- 2) Do not cut the solar cell wire. Discontinue use if the wire becomes frayed or broken.
- 3) Do not immerse components in liquid.
- 4) Do not use any other charge than the single solar charging panel and adaptor provided with the SOLAR PIR SENSOR LIGHT. This may result in injury or damage to the light and voids any warranty.
- 5) Position so that the cord is securely fastened and will not result in a hazard (such as tripping).
- 6) When changing the bulb or battery, be careful of any sharp edges that could cut you or the wires. Do not pull on wires.

■ CLEANING

It is important that the solar panel is kept free of dirt and debris. A dirty solar panel will not allow the battery to fully charge and this will shorten the life of battery and cause the light to malfunction

■ STORAGE

If you wish to store your light indoors for more than two or three days, follow these steps to prevent damage to battery:

1. Turn the switch to OFF position
2. Store the light and solar panel where it can receive some sunlight or room light each day. The battery needs light to maintain a charge during storage
3. During prolonged storage, unit must be fully charge once every four months, for best performance, do not store for prolonged periods.

■ NOTE THE FOLLOWING TROUBLE-SHOOTING:

1. **Symptom:** Light won't activate in normal operation.

Correction: make sure that:

- 1) The main unit switch is the AUTO position.
- 2) The Lux control is not set too far toward (☾)
- 3) The motion sensor is positioned to face oncoming movement
- 4) The solar cell is angled so that it gets plenty of

direct sunlight for most of day, if not the entire day.

- 5) The bulb is not broken or out of its socket. Refer to bulb replacement section.
- 6) Battery charge is not too low (charge for 3 sunny days—switch turned to OFF)

2. **Symptom:** Light turns on during the day.

Correction: Make sure that

- 1) The Lux control is not set too far toward (☀)

3. **Symptom:** Light quickly flashes on and off

Correction:

- 1) Move the Lux control toward (☀)
- 2) Low battery (charge for 3 sunny days—switch turned to OFF).

4. **Symptom:** Light is not as bright as normal.

Correction:

- 1) Replace bulb
- 2) Low battery (charge for 3 sunny days—switch turned to OFF).

Distribute by:

www.symmetryco.com

877-599-3779